



7330 Mono Laser Printer

Quick Use Guide

English EN

Français FR Petit guide d'utilisation

Italiano IT Guida rapida

Deutsch DE Kurzübersicht

Español ES Guía de uso rápido



EN Basic Printing

FR Impression de base

IT Nozioni di base sulla stampa

DE Grundlegende Informationen zum Drucken

ES Impresión básica

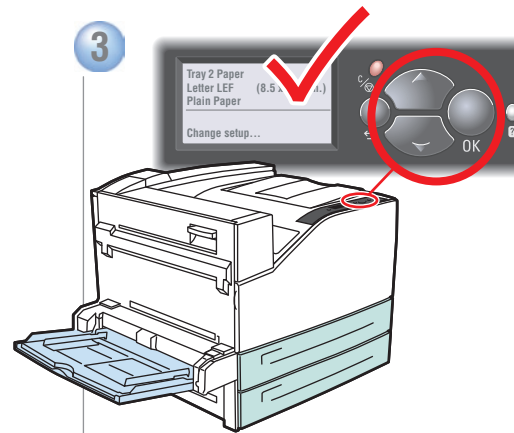
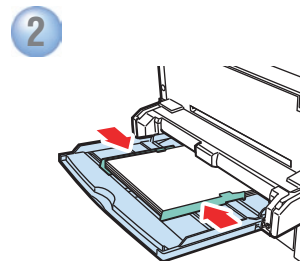
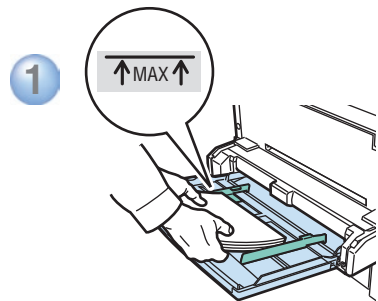
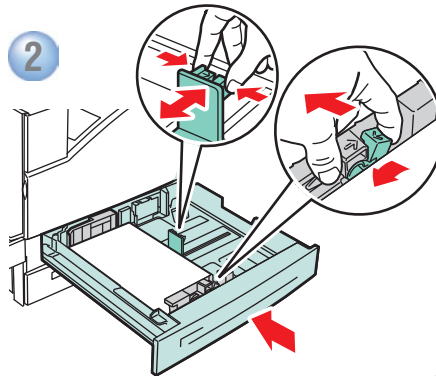
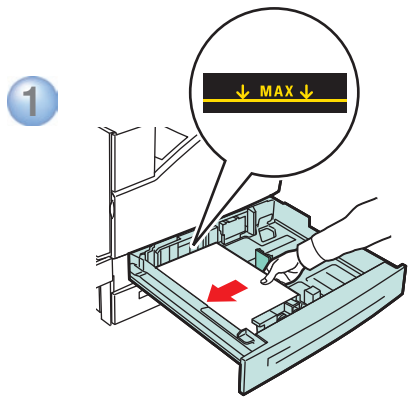
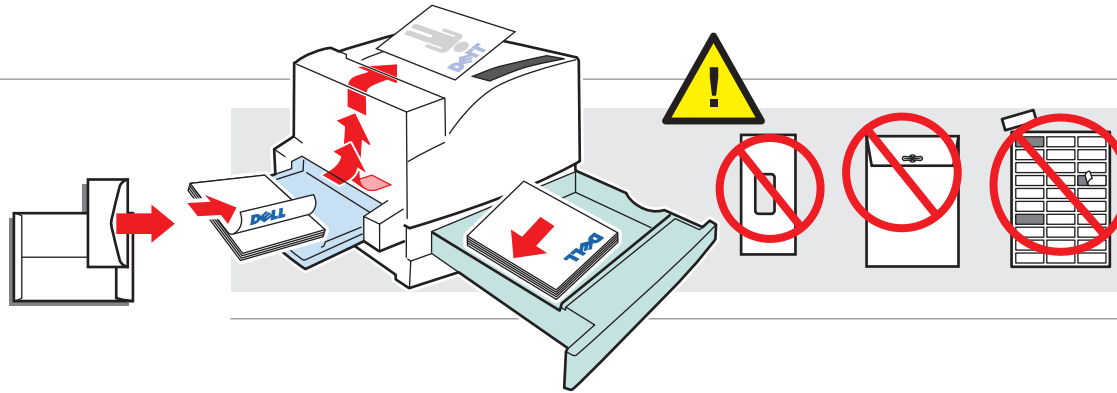

● Confirm or change settings.

FR Confirmez ou changez les paramètres.

IT Confermare o modificare le impostazioni.

DE Einstellungen bestätigen oder ändern.

ES Confirme o cambie los parámetros.

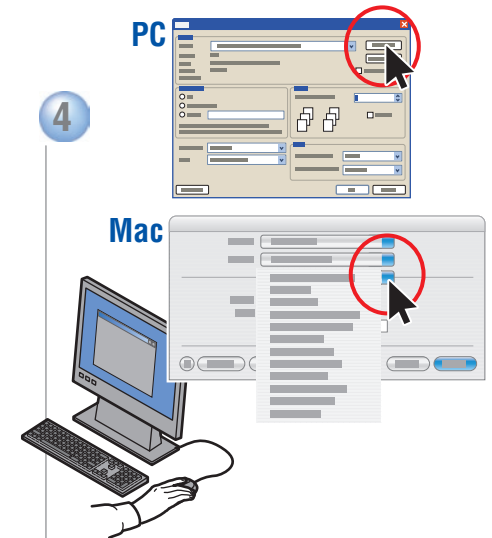

● Select special features in the Dell printer driver.

FR Sélectionnez les fonctions spéciales dans le pilote d'imprimante Dell.

IT Selezionare le funzioni speciali nel driver della stampante Dell.

DE Im Dell-Druckertreiber werden zusätzliche Funktionen ausgewählt.

ES Seleccione las características especiales en el controlador de impresora de Dell.

EN Supported Papers

- FR Papiers pris en charge
- IT Carta supportata
- DE Unterstütztes Papier
- ES Papeles admitidos

Tray 1, 3, 4, 5, 6
60 – 215 g/m²
(16 lb. Bond – 57 lb. Bond/
80 lb. Cover)

Tray 2
60 – 105 g/m²
(16 lb. Bond – 28 lb. Bond)

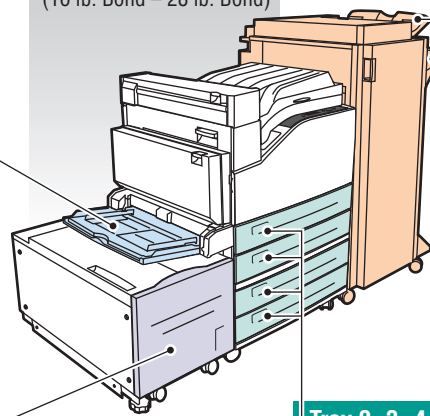

Upper, Lower Tray

Executive	7.25 x 10.5 in.
Letter	8.5 x 11.0 in.
US Folio	8.5 x 13.0 in.
Legal	8.5 x 14.0 in.
Tabloid	11.0 x 17.0 in.
Custom	(SE) x (LE)
A4	210 x 297 mm
A3	297 x 420 mm
B5 JIS	182 x 257 mm
B4 JIS	257 x 364 mm

Tray 1 (MPT)

Small Postcard	3.5 x 5.5 in.
Large Postcard	4.0 x 6.0 in.
Statement	5.5 x 8.5 in.
Executive	7.25 x 10.5 in.
Letter	8.5 x 11.0 in.
US Folio	8.5 x 13.0 in.
Legal	8.5 x 14.0 in.
Tabloid	11.0 x 17.0 in.
Custom	(SE) x (LE)
A6	105 x 148 mm
A5	148 x 210 mm
A4	210 x 297 mm
A3	297 x 420 mm
B6 JIS	128 x 182 mm
B5 JIS	182 x 257 mm
B4 JIS	257 x 364 mm

Tray 6

Executive	7.25 x 10.5 in.
Letter	8.5 x 11.0 in.
A4	210 x 297 mm
B5 JIS	182 x 257 mm

Tray 2, 3, 4, 5

Statement	5.5 x 8.5 in.
Executive	7.25 x 10.5 in.
Letter	8.5 x 11.0 in.
US Folio	8.5 x 13.0 in.
Legal	8.5 x 14.0 in.
Tabloid	11.0 x 17.0 in.
Custom	(SE) x (LE)
A5	148 x 210 mm
A4	210 x 297 mm
A3	297 x 420 mm
B5 JIS	182 x 257 mm
B4 JIS	257 x 364 mm

Letter	8.5 x 11.0 in.
A4	210 x 297 mm

Monarch

# 10	3.87 x 7.5 in.
DL	110 x 220 mm
C5	162 x 229 mm
C4	229 x 324 mm

Letter	8.5 x 11.0 in.
A4	210 x 297 mm

Custom (SE) x (LE)

- FR Personnalisé
- IT Personalizzato
- DE Benutzerdefiniert
- ES Personalizado

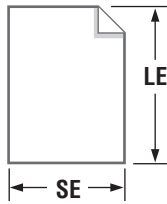

Tray 1 (MPT)	Tray 2, 3, 4, 5
SE.....89–297 mm (3.5–11.7 in.)	SE.....140–297 mm (5.5–11.7 in.)
LE.....98–432 mm (3.87–17.0 in.)	LE.....182–432 mm (7.16–17.0 in.)



- Print the Paper Tips page for more information.

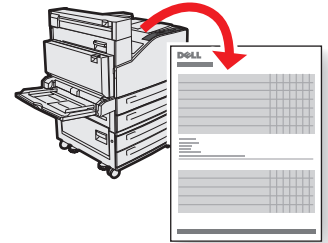

- See the [Printing Basics](#) chapter in the *User Guide*.



- FR • Imprimez la page Conseils Papier pour obtenir plus d'informations.
- Reportez-vous au chapitre [Notions fondamentales sur l'impression](#) du *Guide d'utilisation*.

- IT • Per ulteriori informazioni, stampare la pagina "Suggerimenti sulla carta".
- Vedere il capitolo [Nozioni di base sulla stampa](#) nella *Guida dell'utente*.

- DE • Die Papiertipps-Seite drucken, um weitere Informationen zu erhalten.
- Siehe Kapitel [Grundlegende Informationen zum Drucken](#) im *Benutzerhandbuch*.

- ES • Para obtener más información, imprima la página [Consejos sobre el papel](#).
- Consulte el capítulo [Aspectos básicos de la impresión](#) en la *Guía del usuario*.

Control Panel Buttons

- FR Boutons du panneau de commande
- IT Pulsanti del pannello di controllo
- DE Bedienfeldtasten
- ES Botones del panel de control

Cancel

- FR Annuler
- IT Annulla
- DE Abbrechen
- ES Cancelar

Back

- FR Arrière
- IT Indietro
- DE Zurück
- ES Atrás

Up Arrow

- FR Flèche haut
- IT Freccia su
- DE Pfeil nach oben
- ES Flecha arriba

OK ✓

Help

- FR Aide
- IT Guida
- DE Hilfe
- ES Ayuda

Down Arrow

- FR Flèche bas
- IT Freccia giù
- DE Pfeil nach unten
- ES Flecha abajo

Help Button: Press at any time to display additional information about the message or menu.

Français (FR)

Bouton Aide : Appuyez à tout moment sur ce bouton pour afficher des informations supplémentaires sur le message ou le menu.

Italiano (IT)

Pulsante della guida (?): Premere questo pulsante in qualsiasi momento per visualizzare ulteriori informazioni sul messaggio o sul menu.

Deutsch (DE)

Hilfe-Taste: Mit dieser Taste können weitere Informationen zur Meldung oder zum Menü angezeigt werden.

Español (ES)

Botón Ayuda: Puede pulsarlo en cualquier momento para obtener más información sobre los mensajes o el menú.

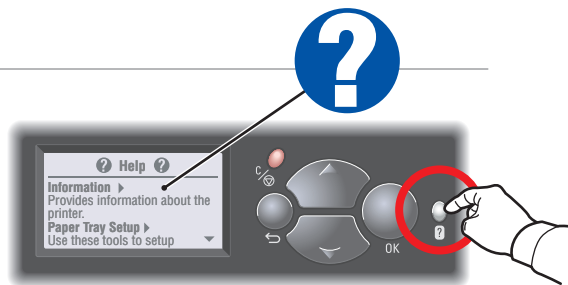

Paper Jams

- FR Bourrages papier
- IT Inceppamenti della carta
- DE Papierstaus
- ES Atascos de papel

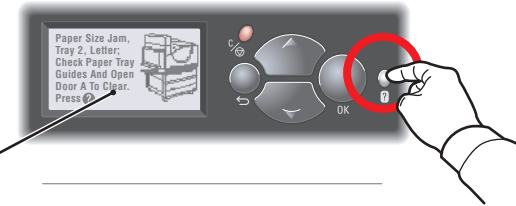

● **Press Help Button** for jam clearing procedures.

● **View Status Monitor message** or see the **Troubleshooting** chapter in the *User Guide*.

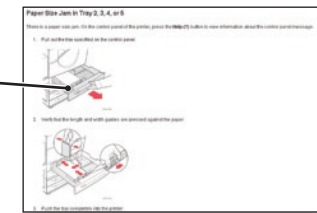

Français (FR)

- **Appuyez sur le bouton Aide** pour savoir comment éliminer le bourrage.
- **Affichez le message Status Monitor** (contrôleur d'état) ou consultez le chapitre **Dépannage** du *Guide d'utilisation*.

Italiano (IT)

- **Premere il pulsante ? (Guida)** per le istruzioni di rimozione degli inceppamenti.
- **Visualizzare il messaggio di Status Monitor** (Monitoraggio stato) oppure vedere il capitolo **Risoluzione dei problemi** nella *Guida dell'utente*.

Deutsch (DE)

- **Hilfe-Taste drücken**, um Informationen zum Beseitigen von Staus anzuzeigen.
- **Meldung im Status Monitor** prüfen oder im Kapitel zur Fehlerbehebung im *Benutzerhandbuch* nachschlagen.

Español (ES)

- **Pulse el botón Ayuda** para saber cómo se despeja un atasco.
- **Vea el mensaje de Status Monitor** (monitor de estado) o consulte el capítulo **Solución de problemas** de la *Guía del usuario*.

EN Printer Tour

- FR Découverte de l'imprimante
- IT Presentazione della stampante
- DE Druckerübersicht
- ES Recorrido por la impresora

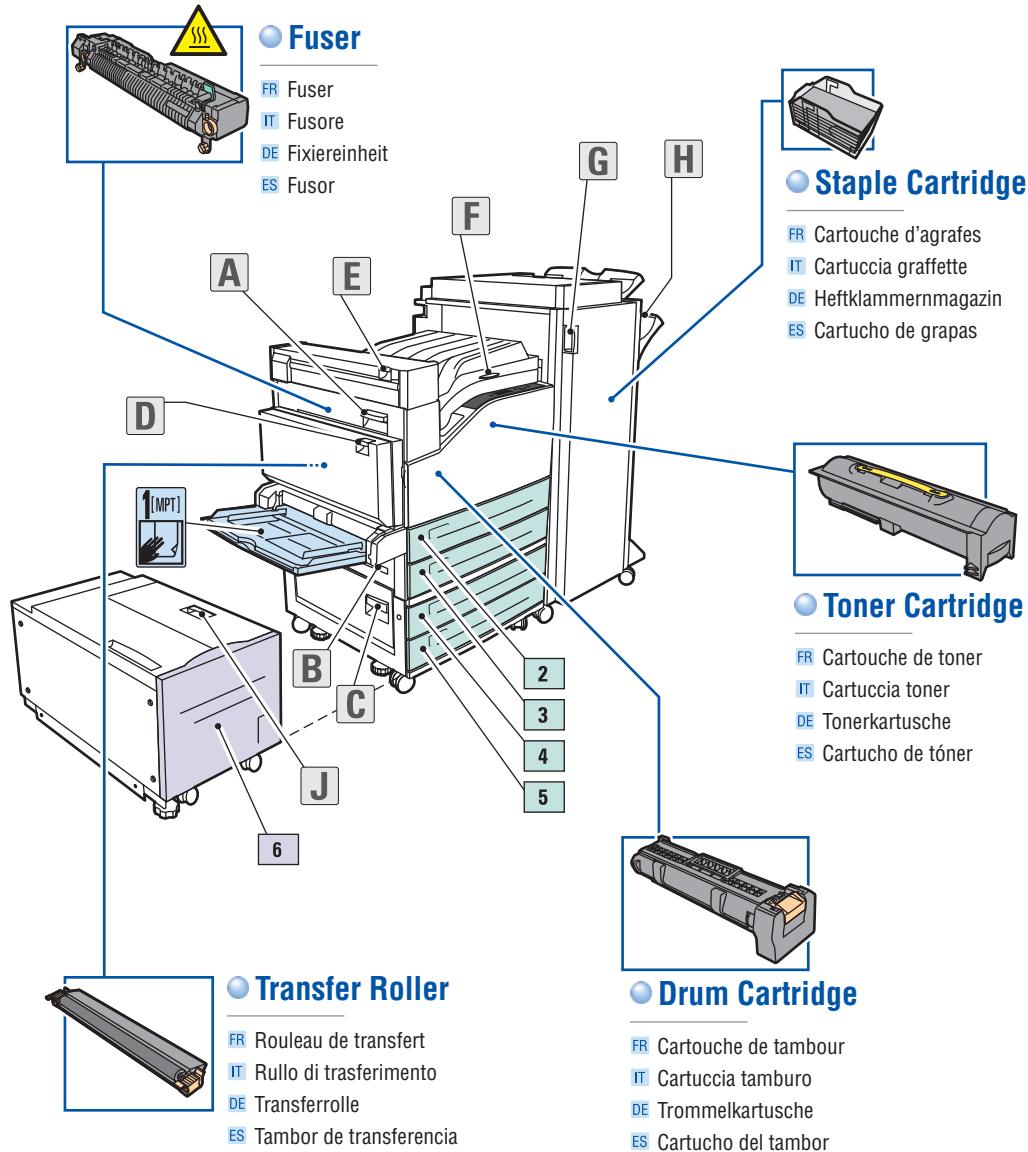

EN Supplies Info

- FR Info consommables
- IT Informazioni sui materiali di consumo
- DE Verbrauchsmaterial-Info
- ES Información de suministros

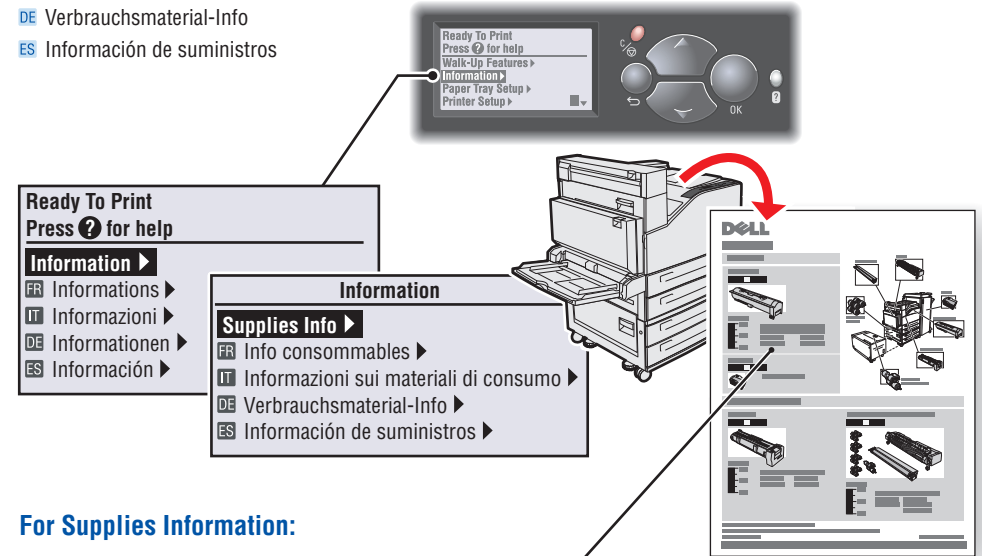

For Supplies Information:

- See the **Supplies Info** menu and print the Supplies Usage page.
- Visit the Dell Supplies website.

www.dell.com/supplies

Français (FR)

Pour des informations sur les consommables :

- Reportez-vous au menu **Info consommables** et imprimez la page Utilisation des consommables.
- Visitez le site des consommables Dell.

Deutsch (DE)

Verbrauchsmaterialinformationen:

- Menü **Verbrauchsmaterial-Info** aufrufen und die Materialverbrauchsseite ausdrucken.
- Dell-Website für Verbrauchsmaterialien.

Italiano (IT)

Per informazioni sui materiali di consumo:

- Consultare il menu **Informazioni materiali consumo** e stampare la pagina "Uso dei materiali di consumo".
- Seguire il collegamento ai materiali di consumo sul sito Dell.

Español (ES)

Para información de suministros:

- Consulte el menú **Información de suministros** e imprima la página Uso de suministros.
- Visite el sitio web de suministros de Dell.

EN Information and Resources

- FR Informations et ressources
- IT Informazioni e risorse
- DE Informationen und Ressourcen
- ES Información y recursos



For drivers and documentation, see your *Software and Documentation* CD, or go to

www.support.dell.com

To order supplies, go to

www.dell.com/supplies

For recycling information, go to

www.dell.com/recycling

Français (FR)

Pour obtenir les pilotes et la documentation, reportez-vous au CD-ROM **Logiciels et documentation** ou rendez-vous sur le site Web www.support.dell.com

Pour commander des consommables, rendez-vous sur le site Web www.dell.com/supplies

Pour obtenir des informations sur le recyclage, rendez-vous sur le site Web www.dell.com/recycling

Italiano (IT)

Per scaricare driver e documentazione, vedere il CD-ROM **del software e della documentazione** oppure visitare il sito www.support.dell.com

Per ordinare i materiali di consumo, visitare il sito www.dell.com/supplies

Per informazioni sul riciclaggio, visitare il sito www.dell.com/recycling

Deutsch (DE)

Treiber und Dokumentation: **Software- und Dokumentations-CD** oder www.support.dell.com

Bestellen von Verbrauchsmaterialien: www.dell.com/supplies

Informationen zum Recycling: www.dell.com/recycling

Español (ES)

Para obtener información sobre controladores y documentación, consulte el CD-ROM de **software y documentación** o visite www.support.dell.com

Para pedir suministros, consulte www.dell.com/supplies

Para obtener información sobre reciclaje, consulte www.dell.com/recycling